

HFG638

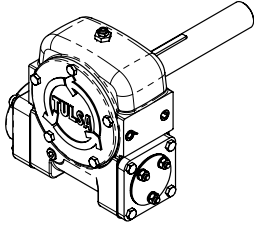

PART #: 83063

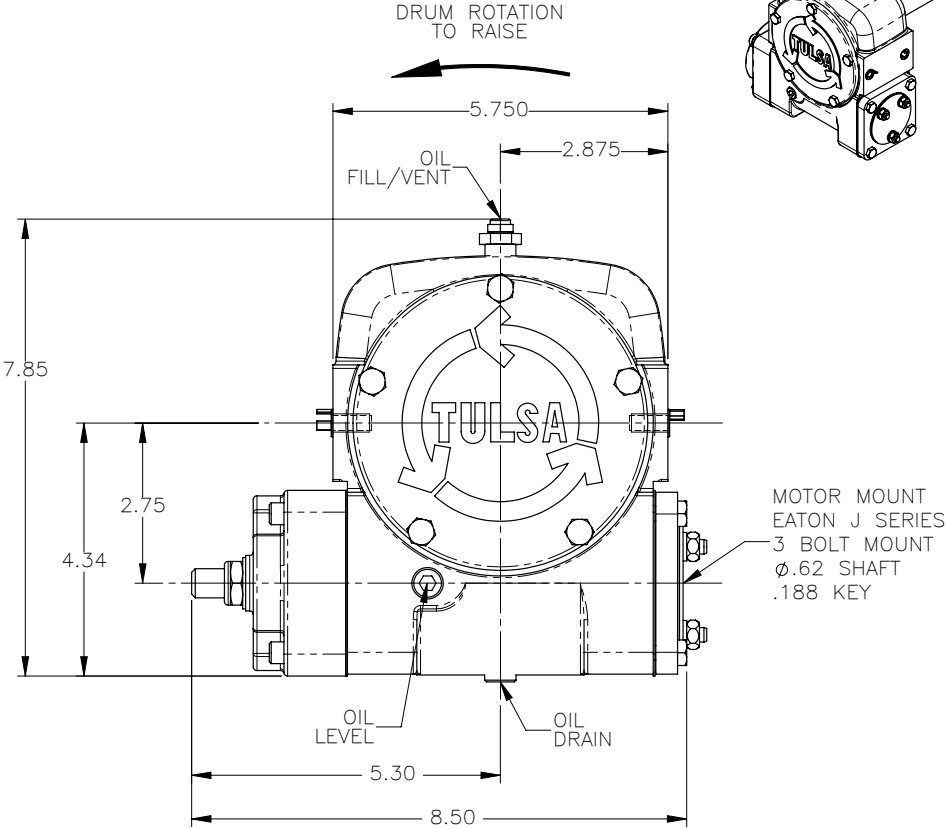
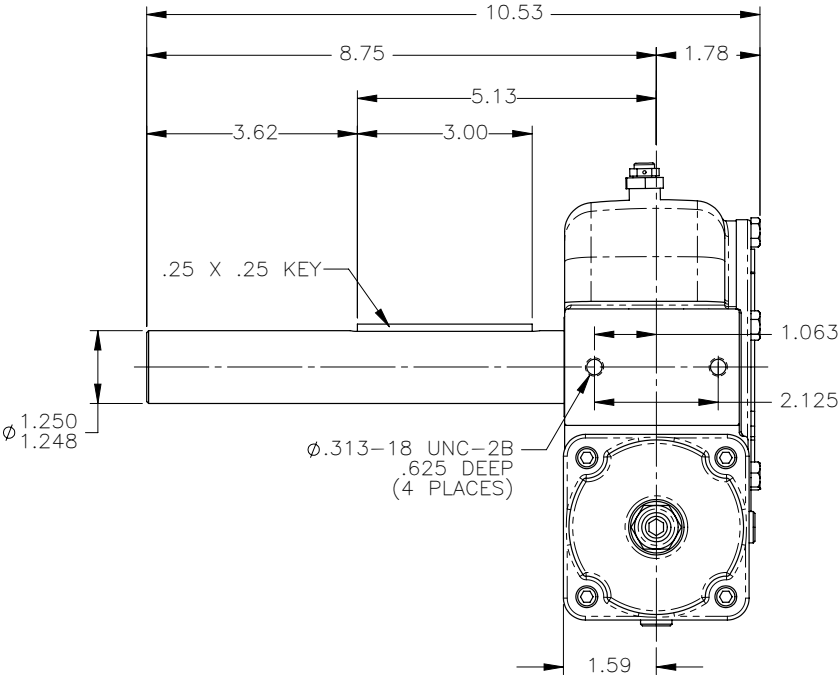
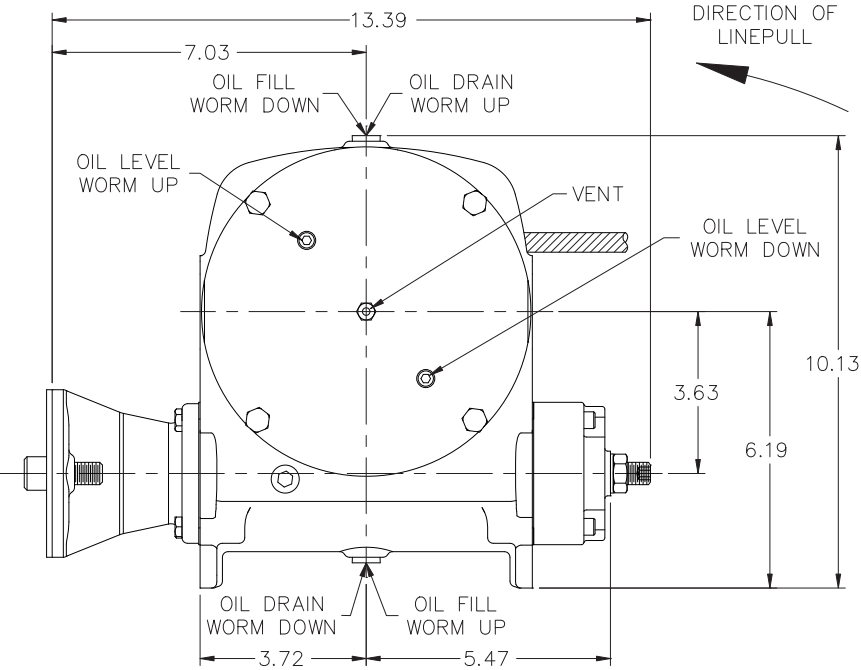
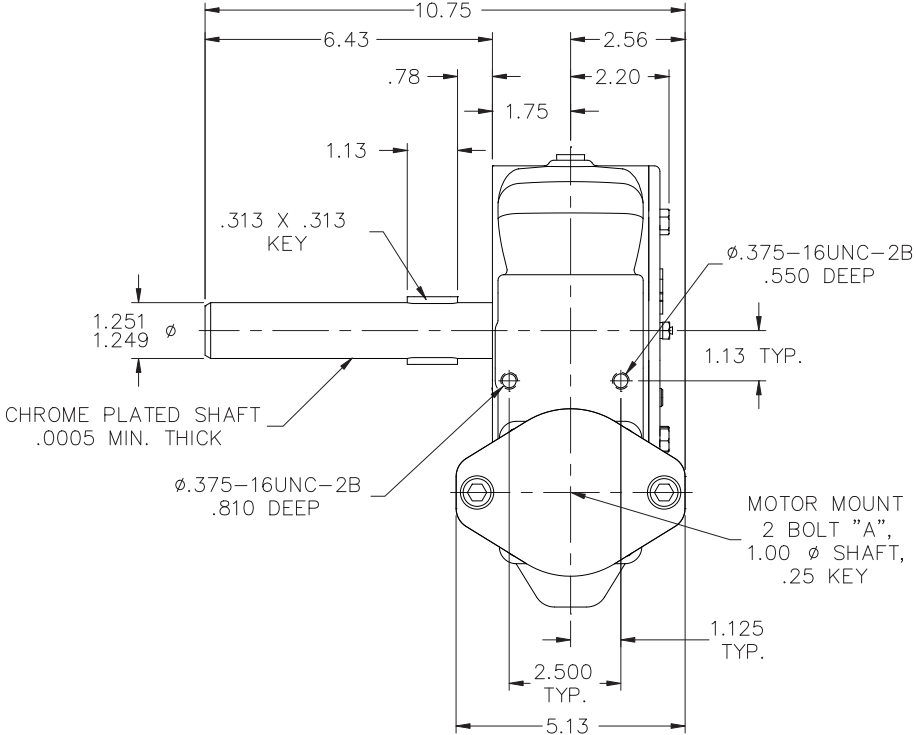

HFG938

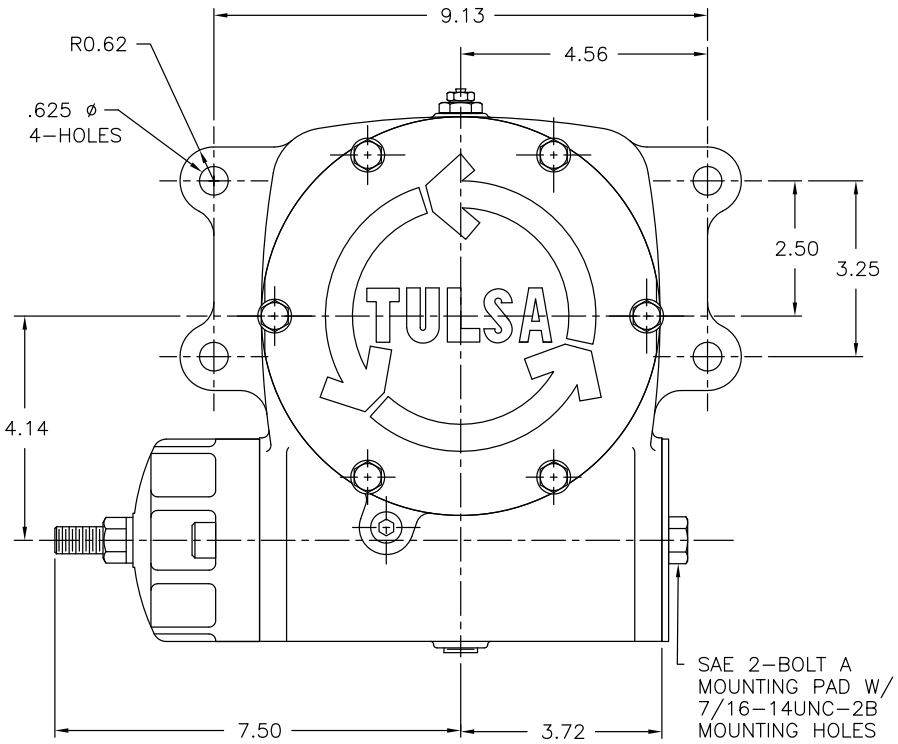
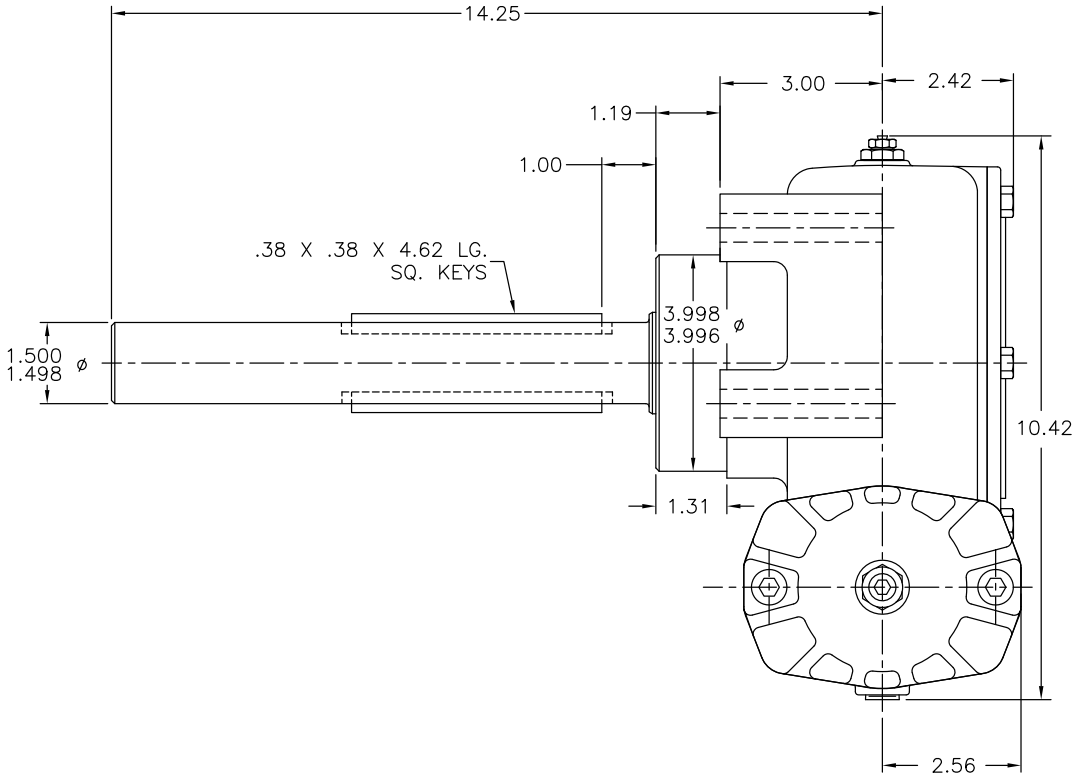

HFG1754

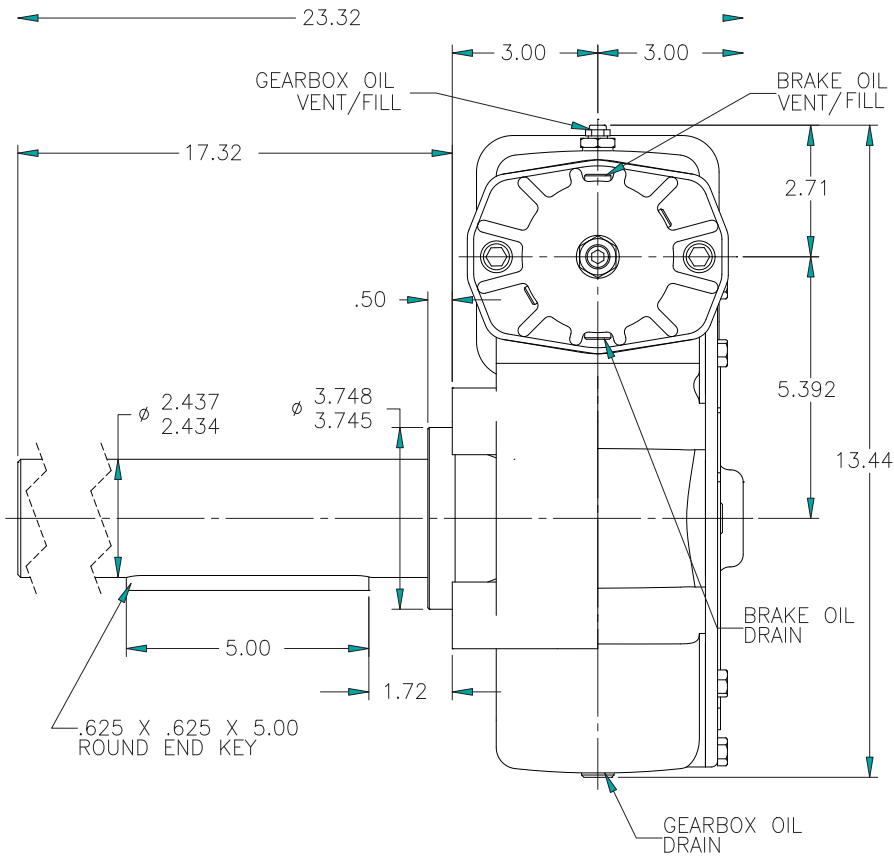

CAD DRAWING DO NOT SCALE
WORK TO DIMENSIONS
REPORT ERRORS

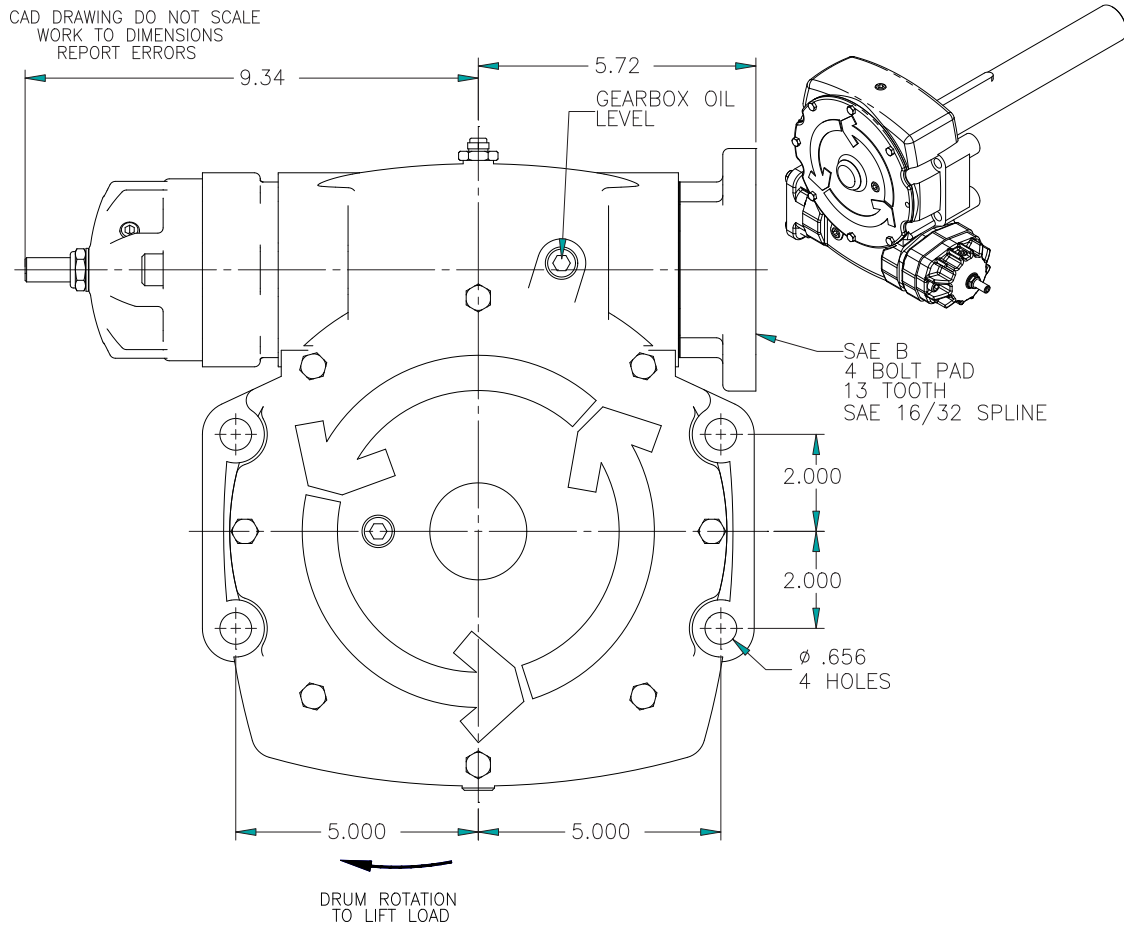

PART #: 80859