

LANTEC

LW Series Winches

A MODULAR LINE OF HYDRAULIC WINCHES

**Line pulls from
12,000 lb to 300,000 lb**



LANTEC

Winch & Gear Inc.

GEAR DRIVES
WINCHES & HOISTS
BRAKES & CLUTCHES

Driven to Excellence

A MODULAR LINE OF
HYDRAULIC WINCHES

This catalogue contains detailed sales information on the LANTEC LW Series Winches. With 20 basic models, a modular design, customizable drums and flexible input options, LANTEC LW Winches suit many applications.

Experience

LANTEC ... Recognized worldwide for providing highly dependable winches, hoists, and planetary drives for the most demanding applications. Over forty years of technical know-how and application experience are brought together with state-of-the-art manufacturing techniques to produce the ultimate in winch reliability, versatility and quality.

Reliability

Our low warranty cost is the envy of the winch industry and is a testament to our rugged, reliable design.



Fast, dependable delivery with competitive pricing. LANTEC is responding to our customer needs for minimal inventory and ever shorter lead times.

LANTEC Winch & Gear is a part of TWG, a global leader in standard and engineered winch, gearbox and load information systems.

reliability versatility quality

modular

lift
lower
pull
position



The LANTEC LW Series Winches are a modular construction consisting of:

Cable Drum Steel cable drum running on rolling bearings. Cable is anchored to the drum using a convenient spiral-ferrule type cable anchor.

Winch Base High strength fabricated steel base for flexible design and maximum rigidity.

Drive Module Pre-packaged two-, three- or four-stage, high-efficiency planetary drive with hardened steel internal gears and case carburized sun and planet gears. Planet gears run on rolling bearings which are replaceable independent of the gear itself. Sun gears float to ensure balanced load distribution.

Brake Module Multi-disc, wet friction brake is spring force applied, hydraulic pressure released. Overrunning clutch is large diameter, high capacity, sprag type. Brake module is standard with SAE C or D motor mount. Optional motor mounts are available.

Hydraulic Motor Standard motor is a durable gear motor designed specifically for winching applications with improved starting torque characteristics. LW Series Winches can be fitted with other motor types including 2-speed gear motors, axial and radial piston motors, and motors for low power systems.

Brake Valve Industry's most stable and reliable counterbalance valve attached directly to the hydraulic motor.

LANTEC LW Series Winches house the planetary reduction gearing and friction brake externally to the drum barrel providing for a very versatile design with the ultimate in performance flexibility.

For applications that require drums with a large D:d ratio (First layer pitch diameter : Cable diameter) and physical compactness consider the LANTEC LH Series Hoists, with the planetary reduction gearing and friction brake housed inside the drum barrel. A wide range of models and drum sizes are available. Please see separate brochure.

LANTEC LW Series Winches are suitable for most crane and lifting applications as well as pulling and positioning. They are available with single drives or dual drives. Dual drives have two motors, two brakes, and two drive modules, for high-horsepower capability.

brake operation

When winching in, the Multi-disc Brake remains applied with the hydraulic motor driving directly into the gear reduction, through an overrunning clutch. When winching stops, the overrunning clutch locks the input shaft to the already applied Multi-disc Brake ensuring no slippage of the load. When powering out, the hydraulic motor is pressurized for the opposite rotation. This pressure is also applied to the Multi-disc Brake, releasing it fully. The Brake Valve then controls the speed of the load in response to the operator demand. When the operator intends to stop, the main control valve is moved to neutral, the pressure diminishes, the Brake Valve closes to stop the load, and the Multi-disc Brake applies as a "parking" brake to positively hold the load.

Features

Typical LW Series Winch

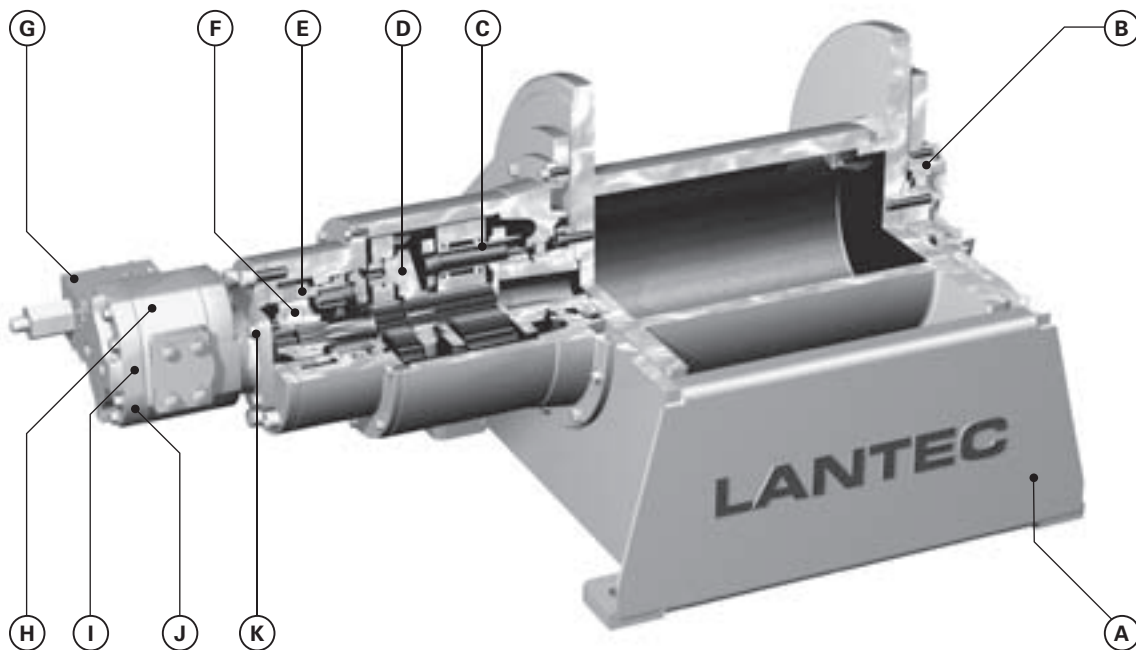

A	High strength fabricated steel base
B	High capacity rolling bearings for long, trouble-free life with minimum maintenance
C	Planet gear rolling bearings, replaceable independent of the gear itself for lower cost rebuilds
D	High-efficiency planetary gearing for optimum performance
E	Multi-disc Brake — spring force applied and hydraulic pressure released for positive load holding
F	Large diameter, high-capacity, sprag type, overrunning clutch for reliable engagement and long life
G	Brake Valve for controlled load movement and high energy transfer rate
H	Standard gear motor for durability
I	Optional 2-speed gear motor for faster “light-load” speeds
J	Optional high-efficiency piston motors to match high-pressure hydraulic systems and achieve optimum winch performance
K	SAE C or D motor mounts to accept a wide variety of motors

features

Many Options and Accessories are available to meet your most demanding applications. Refer to page 10.

Cable Drum Capacities

This chart shows the estimated gross cable capacity (feet) of the drum, assuming proper spooling.

Capacities shown assume a full drum, with the top layer of cable not exceeding the flange diameter. No allowance has been made for "free flange" or "free board" which may be dictated by codes or rules relevant to the application. No allowance has been made for "dead" wraps (mandatory minimum of 3 "dead" wraps of cable to be left on the drum at all times).

LANTEC is pleased to provide a layer-by-layer drum capacity chart upon request.

cable drum capacities

Drum Dimensions (in)				Nominal Wire Rope Diameter (in)																
Drum Number	Barrel Diameter	Flange Diameter	Between Flanges	1/2	5/8	3/4	7/8	1	1 1/8	1 1/4	1 3/8	1 1/2	1 5/8	1 3/4	1 7/8	2	2 1/4	2 1/2		
081	8	18	10	681	436	262	185													
082	8	18	16	1,089	697	419	296													
083	8	18	24	1,634	1,046	628	444													
084	8	24	10	1,340	779	541	428													
085	8	24	16	2,145	1,247	866	684													
086	8	24	24	3,217	1,870	1,299	1,026													
101	10	24	10	1,246	778	526	407	312	234											
102	10	24	16	1,994	1,244	842	651	499	374											
103	10	24	24	2,991	1,866	1,263	977	748	561											
104	10	30	14	2,932	1,877	1,255	904	733	495											
105	10	30	20	4,189	2,681	1,793	1,292	1,047	707											
106	10	30	30	6,283	4,021	2,689	1,938	1,571	1,061											
121	12	26	14		1,218	825	637	488	367	268										
122	12	26	20		1,739	1,178	910	696	524	382										
123	12	26	30		2,609	1,767	1,364	1,045	785	573										
124	12	32	14		2,064	1,382	996	806	547	516										
125	12	32	20		2,949	1,974	1,423	1,152	782	737										
126	12	32	30		4,423	2,961	2,135	1,728	1,173	1,106										
141	14	28	14		1,347	913	704	539	406	297	278	196								
142	14	28	20		1,924	1,304	1,005	770	579	424	398	279								
143	14	28	30		2,886	1,956	1,508	1,155	869	636	596	419								
144	14	36	14		2,455	1,676	1,232	1,008	707	563	533	419								
145	14	36	20		3,507	2,395	1,759	1,440	1,011	804	762	599								
146	14	36	30		5,261	3,592	2,639	2,160	1,516	1,206	1,142	898								
161	16	32	14			1,148	900	704	545	413	305	287	203	193						
162	16	32	20			1,641	1,286	1,005	778	591	436	410	290	275						
163	16	32	30			2,461	1,929	1,508	1,167	886	653	615	435	413						
164	16	40	20			3,128	2,130	1,759	1,268	1,027	823	782	617	476						
165	16	40	30			4,691	3,194	2,639	1,902	1,541	1,234	1,173	926	714						
166	16	40	40			6,255	4,259	3,519	2,537	2,055	1,645	1,564	1,235	952						
181	18	34	20				1,394	1,089	843	641	474	445	316	299	285	272				
182	18	34	30				2,090	1,634	1,265	961	710	668	474	449	427	408				
183	18	34	40				2,787	2,178	1,686	1,282	947	890	632	598	570	545				
184	18	42	20				2,285	1,885	1,361	1,103	884	838	663	512	490	471				
185	18	42	30				3,428	2,827	2,042	1,654	1,325	1,257	994	767	735	707				
186	18	42	40				4,570	3,770	2,723	2,205	1,767	1,676	1,325	1,023	980	943				
201	20	36	20				1,501	1,173	908	691	512	480	342	323	307	293	187			
202	20	36	30				2,252	1,759	1,362	1,037	768	720	512	485	461	440	280			
203	20	36	40				3,003	2,346	1,816	1,382	1,023	960	683	646	614	586	374			
204	20	44	20				2,441	2,011	1,454	1,178	944	894	708	548	524	503	364			
205	20	44	30				3,661	3,016	2,182	1,767	1,417	1,340	1,062	821	785	754	545			
206	20	44	40				4,881	4,021	2,909	2,356	1,889	1,787	1,415	1,095	1,047	1,005	727			
241	24	40	20					1,039	792	588	550	393	371	352	335	215		198		
242	24	40	30					1,558	1,188	882	825	590	557	528	503	322		297		
243	24	40	40					2,077	1,583	1,176	1,100	786	742	704	670	429		396		
244	24	48	20					1,641	1,329	1,066	1,005	798	619	591	566	410		285		
245	24	48	30					2,461	1,993	1,599	1,508	1,197	929	886	848	615		427		
246	24	48	40					3,281	2,658	2,133	2,011	1,596	1,239	1,181	1,131	820		570		
301	30	48	24							1,049	980	737	696	503	478	436		283		
302	30	48	36							1,573	1,470	1,106	1,044	754	716	654		424		
303	30	48	48							2,097	1,960	1,474	1,391	1,005	955	871		566		
304	30	60	24							1,999	1,885	1,553	1,264	1,206	968	729		679		
305	30	60	36							2,999	2,827	2,329	1,896	1,810	1,451	1,093		1,018		
306	30	60	48							3,998	3,770	3,106	2,528	2,413	1,935	1,458		1,357		
361	36	54	24									853	803	583	553	503		328		
362	36	54	36							1,280	1,205	875	829	754	754	492		492		
363	36	54	48							1,706	1,607	1,166	1,106	1,106	1,005	656		656		
364	36	66	24							1,762	1,436	1,367	1,100	829	769			769		
365	36	66	36							2,643	2,154	2,051	1,649	1,244	1,154			1,154		
366	36	66	48							3,523	2,872	2,734	2,199	1,659	1,538			1,538		
421	42	60	36							1,367	995	943	855	560				560		
422	42	60	48							1,822	1,327	1,257	1,139	746				746		
423	42	60	60							2,278	1,659	1,571	1,424	933				933		
424	42	72	36							2,413	2,292	1,847	1,395	1,289				1,289		
425	42	72	48							3,217	3,056	2,463	1,860	1,719				1,719		
426	42	72	60							4,021	3,820	3,079	2,325	2,149				2,149		
481	48	66	36													1,056	955		628	
482	48	66	54													1,583	1,433		942	
483	48	66	72													2,111	1,910		1,255	
484	48	78	36													2,045	1,546		1,425	
485	48	78	54													3,068	2,319		2,138	
486	48	78	72													4,090	3,091		2,850	

Estimated Gross Cable Capacity (ft)
Consult Factory
Not Available

In addition to this list, virtually any drum size is available.
Consult LANTEC for recommendation of a cost-effective solution.

Performance
LWS Series – Single Drive

This table shows the basic performance data and limitations based on the standard gear ratio and motor for each model. Considering the wide variety of winch sizes, gear ratios, hydraulic motor characteristics and hydraulic system performance, the winch selection process can become complex.

Model	Drum Size			Line Pull (Maximum)			Line Speed (Maximum Allowable)			Line Speed (Maximum with Standard Motor)		
	Drum Number	Barrel Diameter	Flange Diameter	1st Layer	Mid Layer	Top Layer	1st Layer	Mid Layer	Top Layer	1st Layer	Mid Layer	Top Layer
		<i>in</i>	<i>in</i>	<i>lb</i>	<i>lb</i>	<i>lb</i>	<i>fpm</i>	<i>fpm</i>	<i>fpm</i>	<i>fpm</i>	<i>fpm</i>	<i>fpm</i>
LWS100	08X	8	24	23,200	16,100	9,000	312	558	803	268	479	690
	12X	12	32	16,100	11,400	6,600	450	774	1,097	387	665	943
	16X	16	40	12,300	8,800	5,200	589	990	1,391	506	851	1,196
LWS160	08X	8	24	35,100	24,600	14,000	207	363	518	177	311	445
	12X	12	32	24,400	17,300	10,200	297	504	710	255	433	610
	16X	16	40	18,700	13,400	8,000	387	645	902	332	554	775
LWS240	10X	10	30	41,900	29,200	16,500	169	300	431	145	258	370
	14X	14	36	31,000	22,300	13,500	229	378	527	197	325	453
	18X	18	42	24,600	18,000	11,400	288	456	623	248	392	535
LWS330	12X	12	32	52,100	37,400	22,600	136	226	315	117	194	270
	16X	16	40	40,100	28,900	17,700	177	289	401	152	249	345
	20X	20	44	32,400	24,200	16,000	219	331	443	188	285	381
LWS430	12X	12	32	64,600	46,600	28,500	110	180	249	94	154	214
	16X	16	40	49,900	36,100	22,300	142	230	318	122	198	273
	20X	20	44	40,400	30,300	20,200	176	264	352	151	227	302
LWS570	14X	14	36	73,600	53,600	33,500	96	154	212	83	133	182
	18X	18	42	58,700	43,500	28,200	121	186	251	104	160	216
	24X	24	48	44,900	34,700	24,400	158	225	291	136	193	250
LWS800	14X	14	36	104,100	76,500	48,900	68	107	145	59	92	125
	18X	18	42	83,300	62,200	41,100	85	129	173	73	111	148
	24X	24	48	63,900	49,700	35,500	111	156	200	95	134	172
LWS1200	16X	16	40	134,900	100,300	65,600	52	79	106	44	68	91
	20X	20	44	111,300	84,900	58,400	62	91	119	54	78	102
	30X	30	60	76,600	59,100	41,600	91	129	167	78	111	144
LWS1700	18X	18	42	175,600	134,000	92,400	40	58	75	34	50	65
	24X	24	48	136,400	107,700	78,900	51	70	88	44	60	76
	36X	36	66	94,000	74,800	55,500	74	100	125	64	86	108
LWS2200	20X	20	44	200,000	155,000	110,000	35	49	63	30	42	54
	30X	30	60	138,600	108,300	77,900	50	70	89	43	60	77
	42X	42	72	101,100	82,500	63,800	69	89	109	59	77	94

LANTEC reserves the right to revise performance figures without prior notice due to further development and technical improvements.

LANTEC recommends allowing our Sales & Application Engineering professionals to assist in determining the winch model and options that satisfy your most demanding applications. LANTEC will be pleased to supply a detailed specification sheet specifically for your application.

Basic Output Data			Basic Input Data			Hydraulic Supply Required with Standard Motor						
Drum Torque Maximum	Drum Speed Maximum Allowable	Drum Speed Maximum with Standard Motor	Standard Gear Ratio	Input Torque Maximum Allowable	Input Speed Maximum Allowable	Standard Motor Maximum Speed	Standard Motor Displacement	Required Pressure (Run)	Required Pressure (Start)	Flow Required at Maximum Speed	Minimum Flow Required for Smooth Performance	Recommended Minimum Flow
<i>lb-in</i>	<i>rpm</i>	<i>rpm</i>		<i>lb-in</i>	<i>rpm</i>	<i>rpm</i>	<i>in³</i>	<i>psi(d)</i>	<i>psi(d)</i>	<i>gpm</i>	<i>gpm</i>	<i>gpm</i>
101,500	136	117	23.49	4,500	3,200	2,750	12.3	2,500	2,870	150	28	50
101,500	136	117	23.49	4,500	3,200	2,750	12.3	2,500	2,870	150	28	50
101,500	136	117	23.49	4,500	3,200	2,750	12.3	2,500	2,870	150	28	50
155,600	89	76	36.00	4,500	3,200	2,750	12.3	2,500	2,870	150	28	50
155,600	89	76	36.00	4,500	3,200	2,750	12.3	2,500	2,870	150	28	50
155,600	89	76	36.00	4,500	3,200	2,750	12.3	2,500	2,870	150	28	50
230,600	59	50	54.46	4,500	3,200	2,750	12.3	2,500	2,870	150	28	50
230,600	59	50	54.46	4,500	3,200	2,750	12.3	2,500	2,870	150	28	50
230,600	59	50	54.46	4,500	3,200	2,750	12.3	2,500	2,870	150	28	50
338,400	40	34	79.91	4,500	3,200	2,750	12.3	2,500	2,870	150	28	50
338,400	40	34	79.91	4,500	3,200	2,750	12.3	2,500	2,870	150	28	50
338,400	40	34	79.91	4,500	3,200	2,750	12.3	2,500	2,870	150	28	50
424,000	32	27	100.10	4,500	3,200	2,750	12.3	2,500	2,870	150	28	50
424,000	32	27	100.10	4,500	3,200	2,750	12.3	2,500	2,870	150	28	50
424,000	32	27	100.10	4,500	3,200	2,750	12.3	2,500	2,870	150	28	50
561,000	24	21	132.55	4,500	3,200	2,750	12.3	2,500	2,870	150	28	50
561,000	24	21	132.55	4,500	3,200	2,750	12.3	2,500	2,870	150	28	50
561,000	24	21	132.55	4,500	3,200	2,750	12.3	2,500	2,870	150	28	50
807,000	17	14	190.59	4,500	3,200	2,750	12.3	2,500	2,870	150	28	50
807,000	17	14	190.59	4,500	3,200	2,750	12.3	2,500	2,870	150	28	50
807,000	17	14	190.59	4,500	3,200	2,750	12.3	2,500	2,870	150	28	50
1,197,000	11	10	288.29	4,500	3,200	2,750	12.3	2,500	2,870	150	28	50
1,197,000	11	10	288.29	4,500	3,200	2,750	12.3	2,500	2,870	150	28	50
1,197,000	11	10	288.29	4,500	3,200	2,750	12.3	2,500	2,870	150	28	50
1,756,000	8	7	423.03	4,500	3,200	2,750	12.3	2,500	2,870	150	28	50
1,756,000	8	7	423.03	4,500	3,200	2,750	12.3	2,500	2,870	150	28	50
1,756,000	8	7	423.03	4,500	3,200	2,750	12.3	2,500	2,870	150	28	50
2,200,000	6	5	529.94	4,500	3,200	2,750	12.3	2,500	2,870	150	28	50
2,200,000	6	5	529.94	4,500	3,200	2,750	12.3	2,500	2,870	150	28	50
2,200,000	6	5	529.94	4,500	3,200	2,750	12.3	2,500	2,870	150	28	50

Performance

LWD Series – Dual Drive

This table shows the basic performance data and limitations based on the standard gear ratio and motor for each model. Considering the wide variety of winch sizes, gear ratios, hydraulic motor characteristics and hydraulic system performance, the winch selection process can become complex.

Model	Drum Size			Line Pull (Maximum)			Line Speed (Maximum Allowable)			Line Speed (Maximum with Standard Motor)		
	Drum Number	Barrel Diameter	Flange Diameter	1st Layer	Mid Layer	Top Layer	1st Layer	Mid Layer	Top Layer	1st Layer	Mid Layer	Top Layer
		<i>in</i>	<i>in</i>	<i>lb</i>	<i>lb</i>	<i>lb</i>	<i>fpm</i>	<i>fpm</i>	<i>fpm</i>	<i>fpm</i>	<i>fpm</i>	<i>fpm</i>
LWD200	10X	10	30	37,300	25,900	14,400	388	698	1,008	333	600	866
	14X	14	36	27,500	19,700	11,800	526	878	1,230	452	755	1,057
	18X	18	42	21,700	15,900	10,000	669	1,057	1,444	575	908	1,241
LWD310	12X	12	32	47,800	34,300	20,700	303	501	698	260	430	600
	16X	16	40	36,900	26,600	16,300	393	642	890	337	551	765
	20X	20	44	29,800	22,300	14,700	486	735	983	417	631	845
LWD460	12X	12	32	69,600	50,500	31,300	204	329	454	175	283	390
	16X	16	40	53,800	39,100	24,400	263	422	581	226	363	499
	20X	20	44	43,900	33,000	22,000	323	485	646	278	417	555
LWD680	14X	14	36	88,100	64,400	40,700	161	255	349	139	220	300
	18X	18	42	70,300	52,300	34,300	202	308	414	173	265	356
	24X	24	48	53,900	41,800	29,600	263	372	480	226	319	412
LWD850	14X	14	36	109,400	80,400	51,400	130	203	276	111	174	237
	18X	18	42	87,500	65,400	43,200	162	245	328	139	211	282
	24X	24	48	67,200	52,300	37,300	211	296	381	182	255	327
LWD1100	16X	16	40	127,400	94,300	61,100	111	172	232	96	148	200
	20X	20	44	104,500	79,700	54,800	136	198	259	117	170	223
	30X	30	60	71,900	55,500	39,100	198	281	363	170	241	312
LWD1600	18X	18	42	162,400	123,400	84,400	87	128	168	75	110	144
	24X	24	48	126,000	99,100	72,100	113	155	197	97	133	169
	36X	36	66	86,400	68,700	51,000	164	221	278	141	190	239
LWD2400	24X	24	48	184,100	146,500	108,800	76	102	128	65	88	110
	36X	36	66	127,200	101,800	76,300	109	146	182	94	126	157
	48X	48	78	96,900	80,300	63,600	143	181	219	123	156	188
LWD3500	24X	24	48	265,100	214,200	163,300	52	69	85	45	59	73
	36X	36	66	184,800	149,100	113,300	75	99	123	65	86	106
	48X	48	78	141,200	117,800	94,300	99	124	148	85	106	127
LWD4400	30X	30	60	270,700	215,400	160,000	51	69	87	44	60	75
	42X	42	72	200,000	164,700	129,400	70	89	107	60	76	92
	48X	48	78	176,000	147,500	118,900	79	98	117	68	85	101

LANTEC reserves the right to revise performance figures without prior notice due to further development and technical improvements.

LANTEC recommends allowing our Sales & Application Engineering professionals to assist in determining the winch model and options that satisfy your most demanding applications. LANTEC will be pleased to supply a detailed specification sheet specifically for your application.

Basic Output Data			Basic Input Data			Hydraulic Supply Required with Standard Motor						
Drum Torque Maximum	Drum Speed Maximum Allowable	Drum Speed Maximum with Standard Motor	Standard Gear Ratio	Input Torque Maximum Allowable	Input Speed Maximum Allowable	Standard Motor Maximum Speed	Standard Motor Displacement	Required Pressure (Run)	Required Pressure (Start)	Flow Required at Maximum Speed	Minimum Flow Required for Smooth Performance	Recommended Minimum Flow
<i>lb-in</i>	<i>rpm</i>	<i>rpm</i>		<i>lb-in</i>	<i>rpm</i>	<i>rpm</i>	<i>in³</i>	<i>psi(d)</i>	<i>psi(d)</i>	<i>gpm</i>	<i>gpm</i>	<i>gpm</i>
203,000	136	117	23.49	4,500	3,200	2,750	12.3	2,500	2,870	300	56	100
203,000	136	117	23.49	4,500	3,200	2,750	12.3	2,500	2,870	300	56	100
203,000	136	117	23.49	4,500	3,200	2,750	12.3	2,500	2,870	300	56	100
311,000	89	76	36.00	4,500	3,200	2,750	12.3	2,500	2,870	300	56	100
311,000	89	76	36.00	4,500	3,200	2,750	12.3	2,500	2,870	300	56	100
311,000	89	76	36.00	4,500	3,200	2,750	12.3	2,500	2,870	300	56	100
461,000	59	50	54.46	4,500	3,200	2,750	12.3	2,500	2,870	300	56	100
461,000	59	50	54.46	4,500	3,200	2,750	12.3	2,500	2,870	300	56	100
461,000	59	50	54.46	4,500	3,200	2,750	12.3	2,500	2,870	300	56	100
677,000	40	34	79.91	4,500	3,200	2,750	12.3	2,500	2,870	300	56	100
677,000	40	34	79.91	4,500	3,200	2,750	12.3	2,500	2,870	300	56	100
677,000	40	34	79.91	4,500	3,200	2,750	12.3	2,500	2,870	300	56	100
848,000	32	27	100.10	4,500	3,200	2,750	12.3	2,500	2,870	300	56	100
848,000	32	27	100.10	4,500	3,200	2,750	12.3	2,500	2,870	300	56	100
848,000	32	27	100.10	4,500	3,200	2,750	12.3	2,500	2,870	300	56	100
1,123,000	24	21	132.55	4,500	3,200	2,750	12.3	2,500	2,870	300	56	100
1,123,000	24	21	132.55	4,500	3,200	2,750	12.3	2,500	2,870	300	56	100
1,123,000	24	21	132.55	4,500	3,200	2,750	12.3	2,500	2,870	300	56	100
1,614,000	17	14	190.59	4,500	3,200	2,750	12.3	2,500	2,870	300	56	100
1,614,000	17	14	190.59	4,500	3,200	2,750	12.3	2,500	2,870	300	56	100
1,614,000	17	14	190.59	4,500	3,200	2,750	12.3	2,500	2,870	300	56	100
2,393,000	11	10	288.29	4,500	3,200	2,750	12.3	2,500	2,870	300	56	100
2,393,000	11	10	288.29	4,500	3,200	2,750	12.3	2,500	2,870	300	56	100
2,393,000	11	10	288.29	4,500	3,200	2,750	12.3	2,500	2,870	300	56	100
3,512,000	8	7	423.03	4,500	3,200	2,750	12.3	2,500	2,870	300	56	100
3,512,000	8	7	423.03	4,500	3,200	2,750	12.3	2,500	2,870	300	56	100
3,512,000	8	7	423.03	4,500	3,200	2,750	12.3	2,500	2,870	300	56	100
4,399,000	6	5	529.94	4,500	3,200	2,750	12.3	2,500	2,870	300	56	100
4,399,000	6	5	529.94	4,500	3,200	2,750	12.3	2,500	2,870	300	56	100
4,399,000	6	5	529.94	4,500	3,200	2,750	12.3	2,500	2,870	300	56	100

Dimensional Data
LWS Series – Single Drive

The dimensions shown are for general information. Only a detailed Certified Installation Drawing, specific to your winch, should be used for final installation dimensions. Certified Installation Drawings are available from LANTEC upon request.

Model	Minimum Flange Diameter	Overall Height	Overall Width	Overall Length	Drum Centerline to Motor End	Drum Axis to Mounting Pads	Base Length
	B	D	E	F	G	H	J
<i>All dimensions are in inches.</i>							
LWS100	16	B + 1 7/8	B + 5 3/8	C + 41 1/8	C/2 + 34 1/2	B/2 + 1 7/8	C + 13 1/8
LWS160	17 1/4	B + 1 7/8	B + 5 3/8	C + 41 5/8	C/2 + 35 1/8	B/2 + 1 7/8	C + 13 1/8
LWS240	19 1/4	B + 1 7/8	B + 5 3/8	C + 45	C/2 + 38 3/8	B/2 + 1 7/8	C + 13 1/8
LWS330	22	B + 2 1/4	B + 6 1/2	C + 45 3/4	C/2 + 39 1/8	B/2 + 2 1/4	C + 13 1/8
LWS430	22	B + 2 1/4	B + 6 1/2	C + 45 3/4	C/2 + 39 1/8	B/2 + 2 1/4	C + 13 1/8
LWS570	22	B + 2 1/4	B + 6 1/2	C + 49 7/8	C/2 + 43 1/4	B/2 + 2 1/4	C + 13 1/8
LWS800	26 1/4	B + 2 1/4	B + 6 1/2	C + 51 1/8	C/2 + 44 3/8	B/2 + 2 1/4	C + 13 1/2
LWS1200	30 1/2	B + 2 1/4	B + 7 1/2	C + 56 3/8	C/2 + 49 3/8	B/2 + 2 1/4	C + 14
LWS1700	34 1/2	B + 2 1/4	B + 7 1/2	C + 57 5/8	C/2 + 50 5/8	B/2 + 2 1/4	C + 14
LWS2200	34 1/2	B + 2 1/4	B + 7 1/2	C + 60 7/8	C/2 + 53 3/8	B/2 + 2 1/4	C + 15

To Determine Winch Dimensions

FIRST

Use the Cable Capacity Chart on page 3 to select the ...

Barrel Diameter (A)

Flange Diameter (B)

(subject to the minimum per table above)

Drum Length Between Flanges (C)

SECOND

Use the formula in the table above to calculate the approximate winch dimensions.

B = Drum Flange Diameter

C = Drum Length Between Flanges

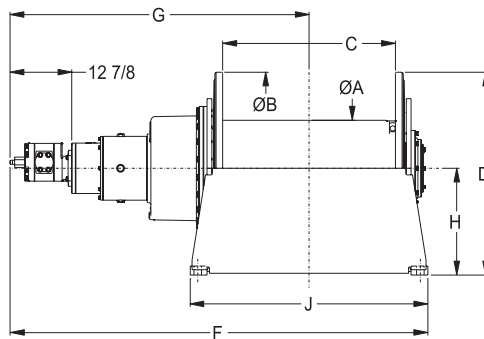
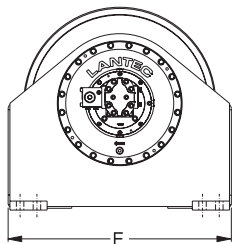
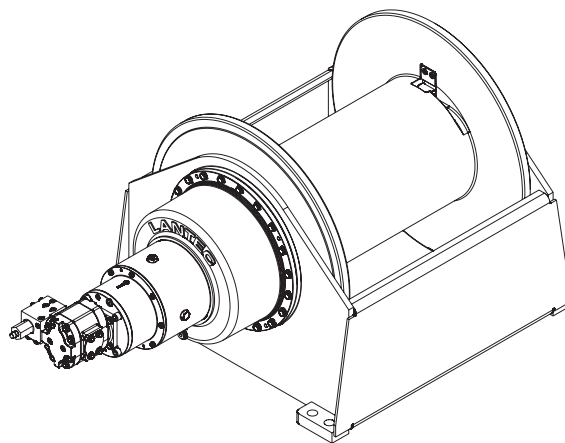

Diagram LWS Series

Specifications subject to change without notice and without incurring obligation. Rely only on a Certified Installation Drawing for accurate and current dimensions.

Dimensional Data
LWD Series – Dual Drive

The dimensions shown are for general information. Only a detailed Certified Installation Drawing, specific to your winch, should be used for final installation dimensions. Certified Installation Drawings are available from LANTEC upon request.

Model	Minimum Flange Diameter	Overall Height	Overall Width	Overall Length	Drum Centerline to Motor End	Drum Axis to Mounting Pads	Base Length
	B	D	E	F	G	H	J
<i>All dimensions are in inches.</i>							
LWD200	16	B + 1 7/8	B + 5 3/8	C + 69	C/2 + 34 1/2	B/2 + 1 7/8	C + 13 1/8
LWD310	17 1/4	B + 1 7/8	B + 5 3/8	C + 70 1/4	C/2 + 35 1/8	B/2 + 1 7/8	C + 13 1/8
LWD460	19 1/4	B + 1 7/8	B + 5 3/8	C + 76 3/4	C/2 + 38 3/8	B/2 + 1 7/8	C + 13 1/8
LWD680	22	B + 2 1/4	B + 6 1/2	C + 78 1/4	C/2 + 39 1/8	B/2 + 2 1/4	C + 13 1/8
LWD850	22	B + 2 1/4	B + 6 1/2	C + 78 1/4	C/2 + 39 1/8	B/2 + 2 1/4	C + 13 1/8
LWD1100	22	B + 2 1/4	B + 6 1/2	C + 86 1/2	C/2 + 43 1/4	B/2 + 2 1/4	C + 13 1/8
LWD1600	26 1/4	B + 2 1/4	B + 6 1/2	C + 88 3/4	C/2 + 44 3/8	B/2 + 2 1/4	C + 13 1/2
LWD2400	30 1/2	B + 2 1/4	B + 7 1/2	C + 98 3/4	C/2 + 49 3/8	B/2 + 2 1/4	C + 14
LWD3500	34 1/2	B + 2 1/4	B + 7 1/2	C + 101 1/4	C/2 + 50 5/8	B/2 + 2 1/4	C + 14
LWD4400	34 1/2	B + 2 1/4	B + 7 1/2	C + 106 3/4	C/2 + 53 3/8	B/2 + 2 1/4	C + 15

To Determine Winch Dimensions

FIRST

Use the Cable Capacity Chart on page 3 to select the ...

Barrel Diameter (A)

Flange Diameter (B)

(subject to the minimum per table above)

Drum Length Between Flanges (C)

SECOND

Use the formula in the table above to calculate the approximate winch dimensions.

B = Drum Flange Diameter

C = Drum Length Between Flanges

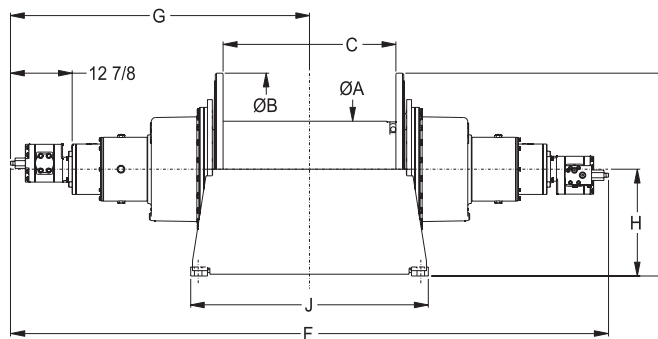
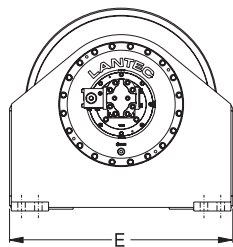
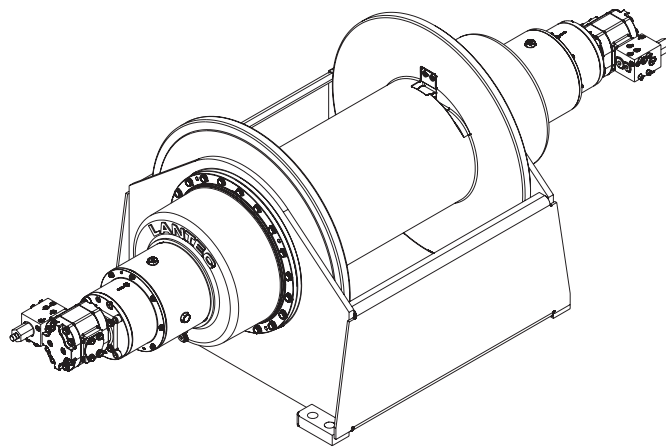

dual drive

Diagram LWD Series

Specifications subject to change without notice and without incurring obligation. Rely only on a Certified Installation Drawing for accurate and current dimensions.

Options & Accessories

LANTEC LW Series Winches are available with a wide variety of optional configurations and accessories to create the winch that meets all your needs.

Drum Configurations Beyond the range of standard drums, LANTEC offers:

- Alternate drum sizes quickly and efficiently manufactured to match your cable storage requirements
- Special cable anchoring methods including synthetic rope anchoring
- Multiple cable anchors for multiple cable or "On-Off" applications
- Drum divider for multiple cable applications
- Grooved drums with spiral grooving
- LeBus® parallel groove drum sleeves

Optional Gear Ratios LANTEC offers optional gear ratios to permit the most economical matching of performance requirements with the available hydraulic power and motor selection.

Hydraulic Motor LANTEC supplies the winch with a hydraulic motor that matches the customer's hydraulic system to provide optimum performance. Winches are also available without motors for customers who prefer to supply their own.

Motor Mounting Configurations LANTEC provides either an SAE C or D motor mount. Other motor mounting configurations are available to support most hydraulic motors including DIN and ISO standards.

Ratchet & Pawl LANTEC offers a spring engaged, hydraulic pressure released ratchet and pawl package. Manual operation is also available.

Multi-disc Brake LANTEC includes a standard multi-disc, friction brake with a sprag type, overrunning clutch for optimum performance in most applications. The brake is available without the overrunning clutch for applications requiring a brake effective in both directions, such as slewing, vanging or positioning.

Drum Brake LANTEC offers a band brake acting directly on the drum. Band brakes are available with a variety of actuator types and in "marine duty" configurations.

Levelwind LANTEC provides a powered levelwind device to assist in proper cable spooling for applications with a large fleet angle.

Drum Pressure Roller LANTEC provides a roller, forced into contact with the cable on the drum by adjustable springs to help prevent "birdsnesting" and assist with cable spooling. This option is also available with sensors indicating top and bottom layer conditions.

Encoder Drive LANTEC offers a light duty output shaft for driving a rotary encoder to monitor winch drum speed and/or position.

© LeBus and the Grooved Sleeve design are Registered Trademarks of LeBus International Inc.

Motor Selection

Standard Motor



Electric Motor



2-Speed Motor



Radial Piston – Fixed and Variable Displacement



Piston – Fixed Displacement



Piston – Variable Displacement

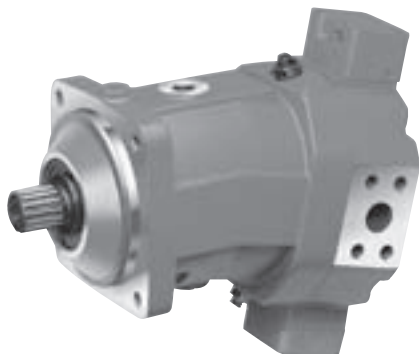

LANTEC LW Series Winches utilize a heavy-duty gear type motor designed with performance characteristics specifically suited to winch applications. This is a time proven and very durable hydraulic motor well suited to most applications.

For high-pressure hydraulics systems employing piston pumps and high-grade system components, we offer LW Series Winches with SAE C or D motor mounting configurations.

LANTEC can supply the winch with a variety of motor types and sizes to best match your system configuration and performance needs.

Some equipment manufacturers prefer to retain complete system responsibility. Therefore, we also offer the LW Series Winch shipped from the factory without a motor. This allows the customer to supply the Motor and Brake Valve that best suits the application.

LANTEC Sales & Application Engineering professionals are pleased to assist customers with appropriate motor selection.

motor selection

Parts
Service
Installation

parts

service

LANTEC stocks all wear parts for quick shipment to any location world wide. Expedited parts service is available for same day shipment if ordered by 11:00 am (PST).

Our Parts professionals work hard to ensure you receive the correct parts for your winch. When a winch serial number is provided with your order we crosscheck to ensure you have ordered the right parts for the job.

LANTEC provides in-factory service and rebuild of your winch including visual inspection, magnetic particle inspection, rebuilding, testing, recertification and recoating.

Factory Authorized Service Centers are conveniently located with factory-trained service personnel to perform troubleshooting, inspection and service.

LANTEC LW Series Winches must be installed in strict accordance with our written installation instructions. The winch must be connected to a suitable hydraulic power supply. Caution: these circuit examples are for illustration purposes only and may not contain all components required for full system function.

Typical Hydraulic Circuit for Standard Motor

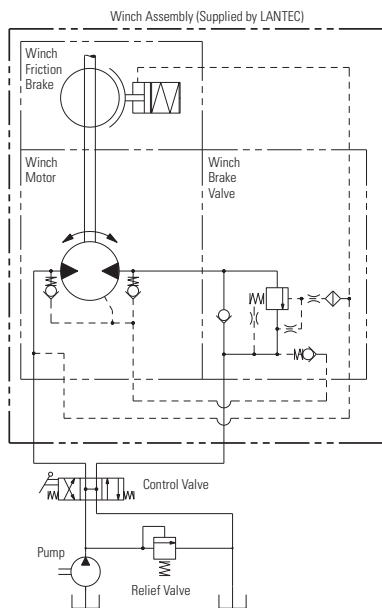

Typical Hydraulic Circuit for 2-Speed Motor

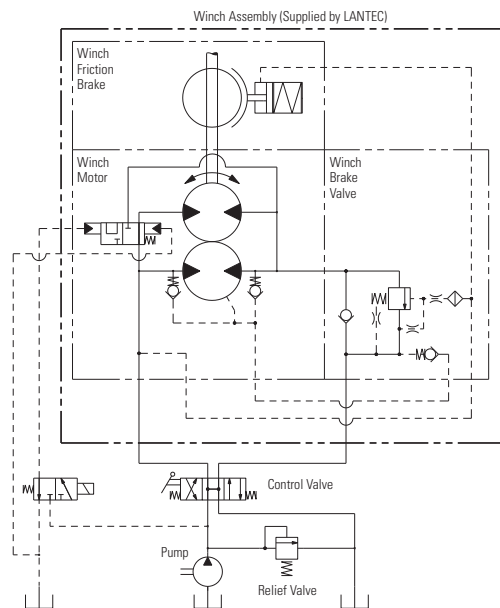

Application Data Sheet

Maximum Line Pull Required	What is the maximum line pull required at the drum for the application? This should take into account the basic payload weight, cable weight, tackle weight, parts of line, sheave efficiency, load dynamics, load acceleration/deceleration time, etc.	<input type="checkbox"/> lb <input type="checkbox"/> ton <input type="checkbox"/> kg <input type="checkbox"/> tonne
Condition for Maximum Pull Requirement	Is this maximum line pull required on the top layer, mid (mean) layer, or first layer?	<input type="checkbox"/> 1st Layer <input type="checkbox"/> Mid Layer <input type="checkbox"/> Top Layer <input type="checkbox"/> Check One
Line Speed Required	What is the line speed required at the drum for the application? This should take into account the parts of line.	<input type="checkbox"/> fpm <input type="checkbox"/> m/min
Condition for Line Speed Requirement	Is this line speed required on the top layer, mid (mean) layer, or first layer?	<input type="checkbox"/> 1st Layer <input type="checkbox"/> Mid Layer <input type="checkbox"/> Top Layer <input type="checkbox"/> Check One
Cable (Wire Rope) Size	Select the appropriate cable size for the application. This selection should consider the maximum load and the factor of safety, which may be dictated by codes or rules relevant to the application.	<input type="checkbox"/> in <input type="checkbox"/> mm
Length of Cable on Drum	Determine the total length of cable to be held on the drum. This should take into account the parts of line in the cable system, the total load travel requirement and over-travel margin. In addition, the cable length on the drum must include the mandatory minimum 3 "dead" wraps of cable to be left on the drum at all times (to supplement the cable termination system and minimize the possibility of reverse wrapping the cable on the drum).	<input type="checkbox"/> ft <input type="checkbox"/> m
Minimum Drum Barrel Diameter	Determine the minimum allowable drum barrel diameter. This is often dictated by codes or rules relevant to the application and often expressed as a "Minimum D:d Ratio", that is, the ratio of first layer pitch diameter to cable diameter. This ratio affects cable bending stress and wear; generally the larger the D:d ratio the longer the cable life will be. LANTEC recommends a minimum of 14:1 for most applications.	<input type="checkbox"/> in <input type="checkbox"/> mm
Hydraulic Power Supply	If the hydraulic system is predetermined, we will use this data to help select the gear ratio and motor size to best suit the performance requirements. If the hydraulic system is not predetermined, then we will advise the requirements based upon optimized selection of gear ratio and motor size.	<input type="checkbox"/> gpm <input type="checkbox"/> lpm <input type="checkbox"/> psi <input type="checkbox"/> bar
Preferred Hydraulic Motor Type	To be indicated if there is a preference.	<input type="checkbox"/> Gear <input type="checkbox"/> Piston <input type="checkbox"/> Check One
Distance to Fixed Sheave	The distance from the cable drum axis to the axis of the first, non-floating sheave. This distance will be used to determine the cable drum width that will ensure proper cable spooling. The shorter the distance the narrower the drum must be.	<input type="checkbox"/> ft <input type="checkbox"/> m

Application Type	Describe General Application
	<hr/> <hr/> <hr/> <hr/> <hr/>



Considering the wide variety of winch sizes, gear ratios, hydraulic motor characteristics and hydraulic system performance, the winch selection process can become complex. LANTEC recommends allowing our Sales & Application Engineering professionals to assist in determining the winch model and options that satisfy your most demanding applications. **For assistance in determining a winch for your application, please copy and fill out this Application Data Sheet and fax to LANTEC at 604-530-2889.**

LANTEC

LH Series Hoists

LANTEC LH Series Hoists are a family of hoists specifically designed for crane applications. With Line Pulls from 12,000 to 72,000 lbs, there's an LH Hoist to suit the most demanding application. Many models have mounting dimensions directly interchangeable with competitive brands.

Please contact LANTEC for more information.

LANTEC

Planetary Drives

LANTEC Planetary Drives are manufactured to meet your application. Current designs include output torques from 10,000 to 500,000 lb-ft. A long history of successful projects assures you of high quality and dependability.

Please contact LANTEC for more information.

LANTEC

Electric Winches

Many of our winch models readily accept electric motors. Today's modern electric drives are well suited for use on winches. If your application requires electric drives, let LANTEC show you our economical solutions.

Please contact LANTEC for more information.

LANTEC

Custom Winches

LANTEC has been designing custom winches for over 40 years. This tremendous experience allows us to assist you in designing and manufacturing the ideal winch for your most demanding projects.



PROUDLY DISTRIBUTED BY

LANTEC
Winch & Gear Inc.

5827 Production Way
Langley, BC V3A 4N5
Canada

Tel (604) 530-0737
Fax (604) 530-2889

sales@lantecgear.com
www.lantecgear.com

LANTEC®



Model 750 Hydraulic Planetary Winch

Line pull of 136,000 lbs. (61,690 kg)

The LANTEC Model 750 Hydraulic Planetary Winch includes a hydraulic gear motor, spring-applied hydraulic-released multidisc brake with overrunning clutch and three planetary gear reductions. The Model 750 is a power in/power out winch with equal speed in both directions. LANTEC specializes in the custom designs, please inquire about special cable drums, hydraulic motors, handbrakes, freespool and ratchet and pawl options to meet your exact application needs.

CAUTION:
The last 5 wraps of cable must be left on the drum to assist the cable anchor in holding the load.

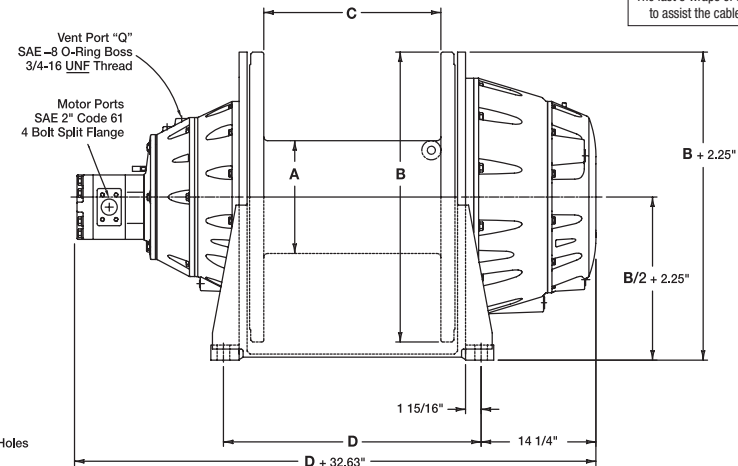
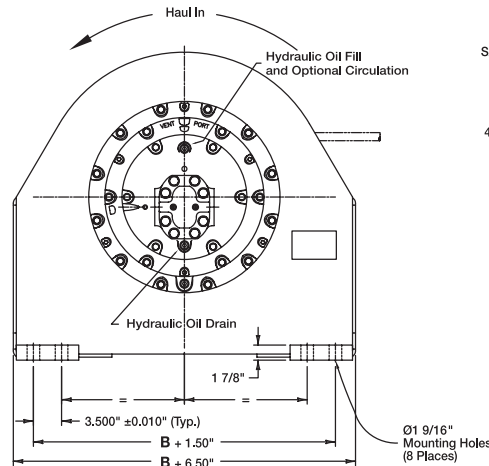

MODEL 750	Drum No.	Line Pull	Line Pull		Line Speed	
			lb.	kg	f.p.m.	m/m
Drum Torque 748,105 lb.in. (84,825 Nm) / Drum R.P.M. 7.81	111-113	Bare	136,000	61,690	22	7
		Mean	70,000	31,752	44	13
		Full	52,700	23,918	58	18
121-123	Bare	99,750	45,246	31	9	
	Mean	65,000	29,484	47	14	
	Full	51,600	23,405	60	18	
131-133	Bare	78,750	35,720	39	12	
	Mean	55,415	25,136	55	16	
	Full	42,750	19,390	72	22	
141-143	Bare	78,750	35,720	39	12	
	Mean	48,264	21,892	63	19	
	Full	36,500	16,556	84	25	
151-153	Bare	59,850	27,148	51	15	
	Mean	45,340	20,566	67	20	
	Full	36,500	16,556	84	25	
161-163	Bare	59,850	27,148	51	15	
	Mean	40,440	18,344	76	23	
	Full	31,835	14,440	96	29	

MODEL 751	Drum No.	Line Pull	Line Pull		Line Speed	
			lb.	kg	f.p.m.	m/m
Drum Torque 561,078 lb.in. (63,394 Nm) / Drum R.P.M. 10.42	111-113	Bare	102,000	46,267	30	9
		Mean	52,500	23,814	58	17
		Full	39,500	17,917	77	23
121-123	Bare	74,810	33,934	41	12	
	Mean	48,790	22,130	62	19	
	Full	38,700	17,554	79	24	
131-133	Bare	59,060	26,790	52	16	
	Mean	41,560	18,852	74	22	
	Full	32,060	14,542	95	29	
141-143	Bare	59,060	26,790	52	16	
	Mean	36,200	16,420	84	25	
	Full	27,370	12,415	112	34	
151-153	Bare	44,890	20,362	68	20	
	Mean	34,000	15,422	90	27	
	Full	27,370	12,415	112	34	
161-163	Bare	44,890	20,362	68	20	
	Mean	30,330	13,758	101	30	
	Full	23,875	10,830	128	39	

MODEL 752	Drum No.	Line Pull	Line Pull		Line Speed	
			lb.	kg	f.p.m.	m/m
Drum Torque 391,055 lb.in. (44,184 Nm) / Drum R.P.M. 14.95	111-113	Bare	71,100	32,250	44	13
		Mean	36,600	16,600	84	25
		Full	28,000	12,700	110	33
121-123	Bare	52,140	23,650	58	17	
	Mean	34,000	15,422	90	27	
	Full	26,970	12,234	114	34	
131-133	Bare	41,164	18,672	74	22	
	Mean	28,968	13,140	106	32	
	Full	22,346	10,136	137	41	
141-143	Bare	41,164	18,672	74	22	
	Mean	25,230	11,444	121	36	
	Full	19,075	8,652	160	48	
151-153	Bare	31,285	14,190	98	30	
	Mean	23,700	10,750	129	39	
	Full	19,075	8,652	160	48	
161-163	Bare	31,285	14,190	98	30	
	Mean	21,140	9,590	145	44	
	Full	16,640	7,548	184	56	

Performance based on a hydraulic volume of 90 gpm [340 l/min] at 2800 psi [193 bar] (2500 psi [172 bar] running)

Contact a TWG sales representative about other available configurations. As a leader in product innovation, TWG is committed to the ongoing improvement of its equipment. TWG reserves the right to make changes to our products without notice.

Drum No.	Dimensions				Cable Capacity Full Drum – No Allowance for Free-Flange													
	A – Barrel Dia.		B – Flange Dia.		C – Length		D – Bolt Centers		7/8"		1"		1 1/8"		1 1/4"		1 3/8"	
	in	mm	in	mm	in	mm	in	mm	ft	mm	ft	mm	ft	mm	ft	mm	ft	mm
111	10	254	30	762	14	356	24.25	616.0	848	258	678	207	438	134	418	127	335	102
112	10	254	30	762	20	508	30.25	768.4	1186	261	994	303	636	194	625	190	467	142
113	10	254	30	762	30	762	40.25	1022.4	1860	576	1518	462	994	303	964	294	716	218
121	14	356	30	762	14	356	23.75	603.3	760	234	600	183	440	134	338	103	246	75
122	14	356	30	762	20	508	29.75	755.7	1082	330	874	266	641	195	505	154	355	108
123	14	356	30	762	30	762	39.75	1009.7	1700	518	1335	407	1000	305	778	237	546	166
131	18	457	36	914	14	356	23.75	603.3	1050	320	826	252	621	189	490	149	372	113
132	18	457	36	914	20	508	29.75	755.7	1470	448	1206	367	904	275	735	224	536	163
133	18	457	36	914	30	762	39.75	1009.7	2308	703	1842	561	1412	430	1124	342	824	251
141	18	457	42	1067	20	508	30.25	768.4	2100	640	1788	545	1224	375	1033	315	790	240
142	18	457	42	1067	30	762	40.25	1022.4	3300	1004	2730	832	1914	583	1580	482	1214	370
143	18	457	42	1067	40	1016	50.25	1276.4	4400	1340	3674	1120	2600	792	2135	650	1698	518
151	24	610	42	1067	20	508	29.75	755.7	1800	548	1476	450	1105	337	900	274	658	200
152	24	610	42	1067	30	762	39.75	1009.7	2826	861	2250	686	1728	527	1380	420	842	256
153	24	610	42	1067	40	1016	49.75	1263.7	3770	1150	3030	924	2352	717	1860	566	1425	434
161	24	610	48	1219	20	508	30.25	768.4	2526	770	2148	655	1475	450	1245	380	952	290
162	24	610	48	1219	30	762	40.25	1022.4	3970	1210	3275	998	2306	703	1908	580	1466	447
163	24	610	48	1219	40	1016	50.25	1276.4	5300	1614	4410	1344	3140	957	2575	785	2060	628

Other drum sizes available. For optimum performance in your operating conditions, please consult with the TWG/LANTEC Engineering Staff for accurate evaluation of all options and specifications.

LANTEC® is a registered brand of TWG, a global leader in standard and engineered winch, gear-box and electronic monitoring systems.

LANTEC®
5827 Production Way
Langley, BC, Canada V3A 4N5
Phone: 604-530-0737
Fax: 604-530-2889

TWG
PO Box 1130
Jenks OK 74037-1130 USA
Phone: 918-298-8300
www.team-twg.com

